

WJ JACUZZI ENERGIZER PARTS LIST

BAG KIT

QTY	PART #	DESCRIPTION	ITEM CK.
1	B-1007	THRUST BEARING	
8	F20LW	LOCKWASHER, 5/16	
8	F21CS	HEX HEAD CAP SCREW, 5/16-18 X 1-1/4	
1	K-4007	SHIM KIT W / 3 EXTRA .060 SHIMS	
1	O-2002	O-RING, TRANSOM	
1	O-3101	O-RING, BOWL	
1	O-3108	O-RING, WJ BEARING HOUSING	
2	O-3208	O-RING, WJ NOZZLE, WJ INSPECTION COVER	
1	SH-1507	SNAP RING, SHAFT	
1	SH-2108	LIP SEAL BACK-UP PLATE	
2	SH-2005	THRUST WASHER	
1	SH-3007	IMPELLER KEY	
1	SH-3507	IMPELLER LOCK NUT	
1	SL-1107	SEAL, BEARING CAP	
2	SL-3708	SEAL, BEARING HOUSING	

ADDITIONAL ITEMS

QTY	PART #	DESCRIPTION	ITEM CK.
1	SH-1108	PUMP SHAFT, WJ ENERGIZER	
1	SC-9208	BOWL ASSEMBLY, JACUZZI WJ	
1	WR-5900	WEAR RING, SIZE STANDARD (WJ)	
1	WR-6004	WEAR RING INSULATOR	
1	G-2507	GASKET, NOZZLE HOUSING	
1	G-1108	GASKET, INTAKE (WJ)	
1		WJ INSTRUCTIONS	
1	IM	IMPELLER	
1	M-2007	SFR PUMP GREASE	
1	R	STEERING W/RUDDER	

AMERICAN TURBINE, INC.

3692 RIVERSIDE DRIVE
ASOTIN, WA 99402
509-243-5387 FAX 509-243-5391

JACUZZI ENERGIZER WJ INSTALLATION INSTRUCTIONS

1. Remove pump from boat.

- a. Disconnect all control cables steering and reverse.
- b. Unbolt transom adapter from hull. Cut all silicone with razor and gently pry from transom. Slip off over bowl and nozzle. It will probably be necessary to remove rudder at this point.
- c. Unbolt all bolts from suction flange located in very bottom of boat. The back two bolts screw in from the bottom.
- d. Break gasket seal and remove from boat.

2. Completely disassemble pump.

- a. Remove eight (8) 3/8-16 x 1-1/2 bolts from bowl suction flange. Break gasket seal and remove bowl assembly.
- b. Remove impeller nut. Do not remove impeller at this time.
- c. Remove bearing cap from front of suction piece.
- d. With large dead - blow hammer (or shop hammer and 2x4) drive the shaft and impeller assembly against wear ring to remove impeller. Remove impeller. Remove key (dikes or side cutters work best).
- e. Pull shaft from suction. Remove seal assembly (note sequence of parts so they can be placed on new shaft properly).
- f. Remove wear ring.

3. Clean up.

- a. Clean excess grease from bearing bore of suction with solvent or soap and water. Clean suction piece and bearing cap.
- b. Remove bearing cap seal.
- c. Remove bearing housing seals.

4. Building a Jacuzzi "WJ " Energizer pump.

- a. Place insulator WR6004 into wear ring bore. Coat insulator with WD-40
- b. Start wear ring WR5900 into wear ring bore (note: wear ring installs easier if it has been in the freezer for four hours).
- c. Tap wear ring all the way in until it bottoms out. Make sure wear ring is square (within) 0.004" of suction flange.

5. Shaft Assembly. (See drawing)

- a. Install thrust washer, thrust bearing, thrust washer, and snap-ring on shaft as shown.
- b. Install seals SL3708 and **NEW** lip seal back up plate SH2108 into bearing housing.
- c. Seals install so that the lip (spring side) faces the impeller with the back up plate between them.

- d. The two seals and the back up plate are pressed together and are flush with the end of the bearing housing that has the o-ring, also the lip seal back up plate has a drain hole that must be installed in the six o'clock position.
- e. Place new o-ring onto bearing housing.
- f. Install new shaft assembly into bearing housing.
- g. Install shaft assembly and bearing housing into suction housing.
- h. Use original bolts and torque to 25 ft/lbs.
- i. Install new bearing cap seal SL1107 into bearing cap with spring towards bearing.
- j. Slide the bearing cap over the shaft with a wiggling motion to prevent damage to the seal.
- k. Use original bolts torque to 25 ft/lbs.

6. Install Impeller.

- a. Slip impeller over shaft (without key) to shoulder of shaft. Add impeller shims as needed to attain .025 to .035 clearance between impeller and front shoulder of wear - ring (see drawing). Place 1/4 x 2-1/2 key in key way. Replace impeller. Lubricate threads with anti - seize or bearing grease to reduce corrosion. Tighten impeller nut to 70 ft/lbs.

7. Install Bowl Assembly.

- a. Place bowl O-Ring on suction.
- b. Install bowl onto suction, be careful you don't damage the seals.
- c. Start all 3/8" bolts and lock washers. Snug four bolts at 90-degree increments and turn shaft by hand. No resistance or noise should be noticed between impeller and wear ring. If resistance is felt realign the bowl. Do this by loosening the bolts and pulling up on the shaft through the inspection cover and retighten. Secure all bolts and torque to 25 ft/lbs.
- d. Install bowl plug.
- e. Grease bowl bearing (about 18 squirts)
- f. Install steering assembly.
- g. Do not install inspection cover yet.
- h. Remove plug from bearing cap and grease thrust bearing with grease provided. Pump until grease comes out the vent hole.

8. Install pump.

- a. Clean all silicone and gasket material from intake and transom.
- b. Smooth a light film of silicone sealer on intake flange. Place base gasket on intake and carefully align holes. Let it set until gasket is secure.
- c. Installing the pump is a 2-man job.
- d. Get in the boat and have your helper set the pump through the transom hole. Try not to slide the pump on gasket. Lift pump slightly to clear gasket. Position pump almost to the drive shaft. Hold drive shaft straight with one hand and with the other hand through the inspection hole, rotate shaft to align splines. Start all bolts. Back two bolts start from bottom.

9. Replace Transom Adapter.

- a. Slip transom adapter over bowl and secure to transom. (Note the inside of the transom adaptor may have to be ground to get enough tilt to bolt to the transom)
- b. Run a small bead of silicone around bowl and transom adapter flange.
- c. Install tiller arm and attach steering cable. Check and adjust for center. Turn steering wheel all the way from one side to the other. Counting the revolutions and turn back half - way centering the steering wheel. Align the steering nozzle with the boat. Adjust steering tube to line up cable with the tiller. Bolt together with 3/8 x 1 1/2 bolt. Hex nut and nylon nut.
- d. Install reverse cable using the cable adapter provided; slide the adapter over the cable. The lock pinhole goes down; place the cotter pin through the pinhole into the

groove on the cable. Place the reverse clevis on cable and insert into reverse bucket lever.

- d. Shift lever to full reverse and make sure bucket completely closes. Adjust if necessary, by moving the cable adapter up or down.
- e. Install hand hole cover. Make sure rubber o-ring is in good shape. If not, replace it. Do not use silicone,
- f. Grease thrust bearing every 8 hours about 4-5 pumps.

- i. Check for leaks.

IF YOU REQUIRE HELP CALL (509) 243-5387 8:00-5:00 PT

IMPELLER / WEAR RING SHIMMING INSTRUCTIONS

Tools needed:

1. .030 feeler gauge
2. propane torch
3. bent screwdriver
4. WD-40
5. Impeller wrench
6. 3/4 wrench
7. 9/16 wrench
8. dead blow hammer

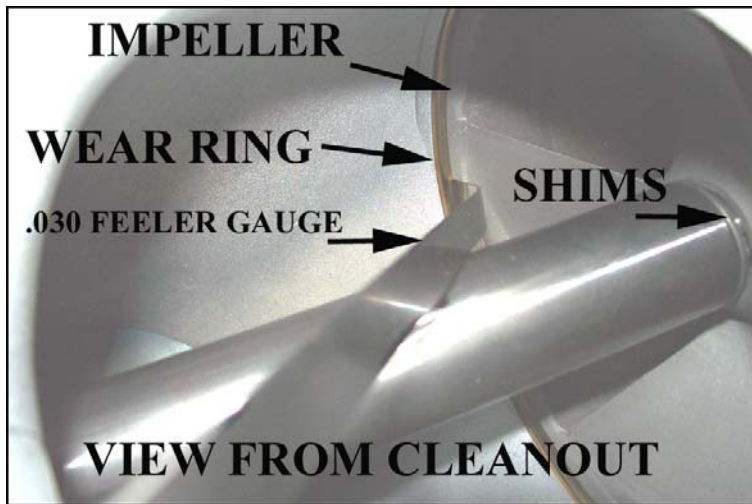

To remove old wear ring:

Use a propane torch. Place the flame on the brass ring go around in a circular motion until the insulator starts to melt. Grab the ring with a bent over screwdriver (90deg.) and pull out. Clean up wear ring bore.

Installation:

Place wear ring in freezer for four hours. Place insulator in suction bore. Spray with WD-40. Start wear ring by hand. Tap wear ring in using a wooden block and a mallet. You may use an old impeller but it may bottom out on the shaft before seating the ring.

Important:

Wear ring must be seated square in the bore with-in 0.004" side to side.

The axial clearance between the impeller and the impeller shoulder must be 0.025"-0.035" (check several places around the wear ring). Check again after the impeller nut has been tightened.

Torque impeller nut to 70 ft/lbs. Torque bowl bolts to 50 ft/lbs.

AMERICAN TURBINE

JACUZZI WJ ENERGIZER KIT

PART # K2108

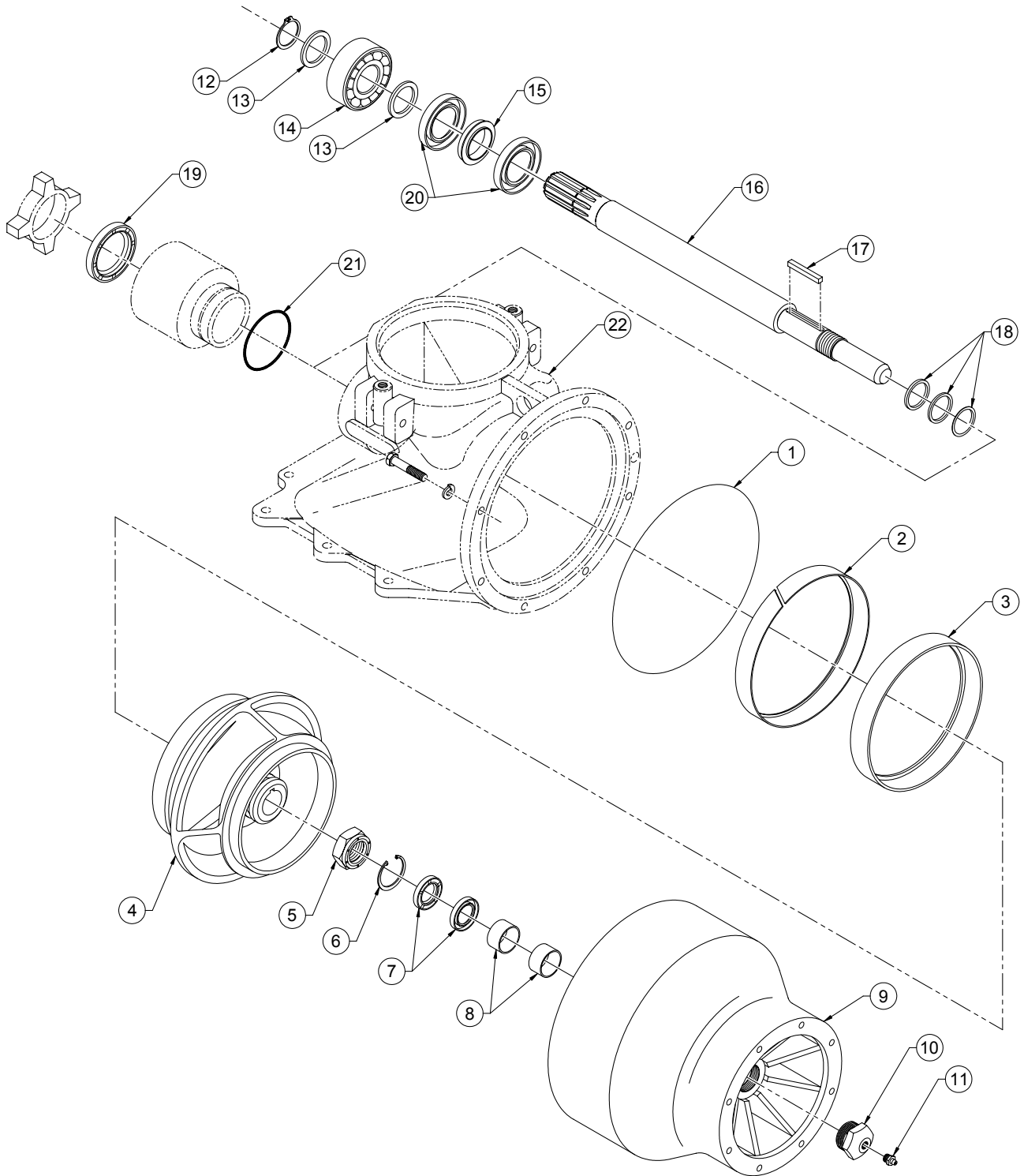

AMERICAN TURBINE

JACUZZI YJ ENERGIZER KIT



LEGEND

SYM.	DESCRIPTION	QTY.	PART NO.	SYM.	DESCRIPTION	QTY.	PART NO.
1	BOWL ORING	1	O3101	12	SHAFT SNAP RING	1	SH1507
2	WEAR RING LINER	1	WR6004	13	THRUST WASHER	2	SH2005
3	WEAR RING	1	WR5900	14	THRUST BEARING	1	B1007
4	IMPELLER	1	IM****	15	SPACER, LIP SEAL	1	SH2108
5	IMPELLER NUT	1	SH3507	16	PUMP SHAFT	1	SH1108
6	BOWL SNAP RING	1	SC9201	17	IMPELLER KEY	1	SH3007
7	BOWL SEAL	2	SL2003	18	SHIMS	1	K4007
8	BOWL BEARINGS	2	B1502	19	BEARING CAP SEAL	1	SL1107
9	BOWL	1	SC9301	20	SEAL, LIP SEAL	2	SL3508
10	BOWL PLUG	1	SC9001	21	O-RING, BEARING HOUSING	1	O3108
11	BOWL PLUG ZERT	1	SC8901	22	12WJ SUCTION	1	****